

# WÓZEK DO TRANSPORTU TALERZY TELLERSTAPLER PLATE STACKING TROLLEY

## 664001



PL

DE

EN

## 1. INFORMACJE

	<b>Element / Artikel / Item</b>	<b>Ilość / Menge / Quantity</b>
<b>1</b>	Profil górny / Profil oben / Profile Top	1
<b>2</b>	Profil dolny / Profil unten / Profile bottom	1
<b>3</b>	Profil L1 / L1 Profil / L1 Profil	1
<b>4</b>	Profil R1 / R1 Profil / R1 Profil	1
<b>5</b>	Profil L2 / L2 Profil / L2 Profil	1
<b>6</b>	Profil R2 / R2 Profil / R2 Profil	1
<b>7</b>	Element montażowy / Befestigungselement / Mounting element	2
<b>8</b>	Śruby motylkowe / Schmetterlingsschrauben / Butterfly screws	8

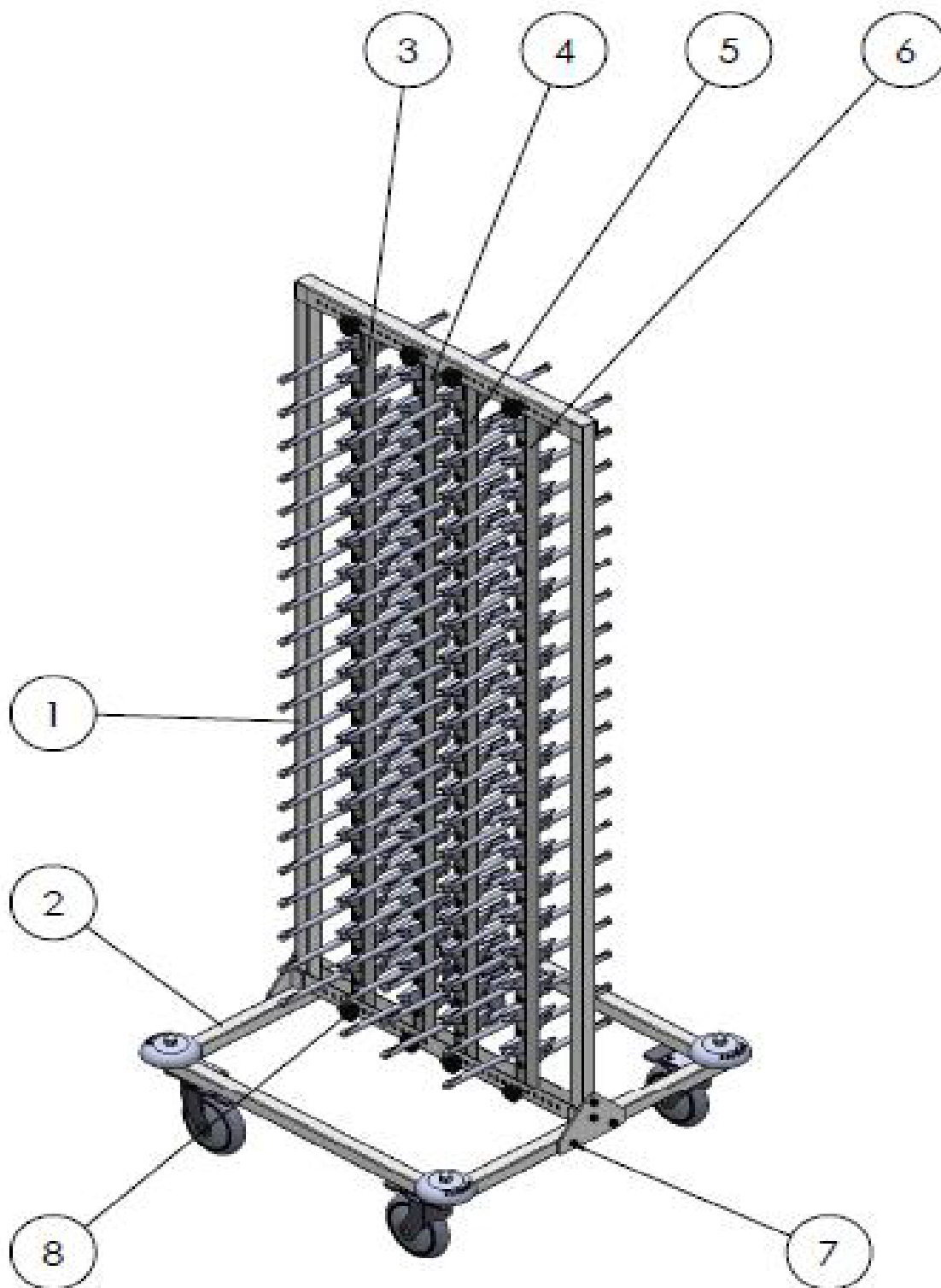

## 2. MONTAŻ WÓZKA / MONTAGE DES TROLLEYS / TROLLEY ASSEMBLY

### 2.1. Krok 1 / Schritt 1 / Step 1

	Element / Artikel / Item	Ilość / Menge / Quantity
1	Profil górny / Profil oben / Profile Top	1
2	Profil dolny / Profil unten / Profile bottom	1
3	Element montażowy / Befestigungselement / Mounting element	2

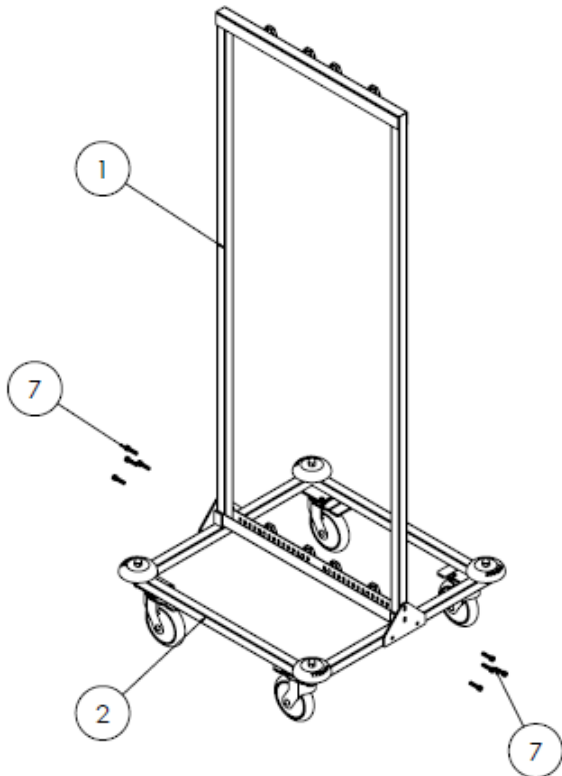

### 2.2. Krok 2 / Schritt 2 / Step 2

	Element / Artikel / Item	Ilość / Menge / Quantity
1	Profil L1 / L1 Profil / L1 Profil	1
2	Profil R1 / R1 Profil / R1 Profil	1
3	Profil L2 / L2 Profil / L2 Profil	1
4	Profil R2 / R2 Profil / R2 Profil	1

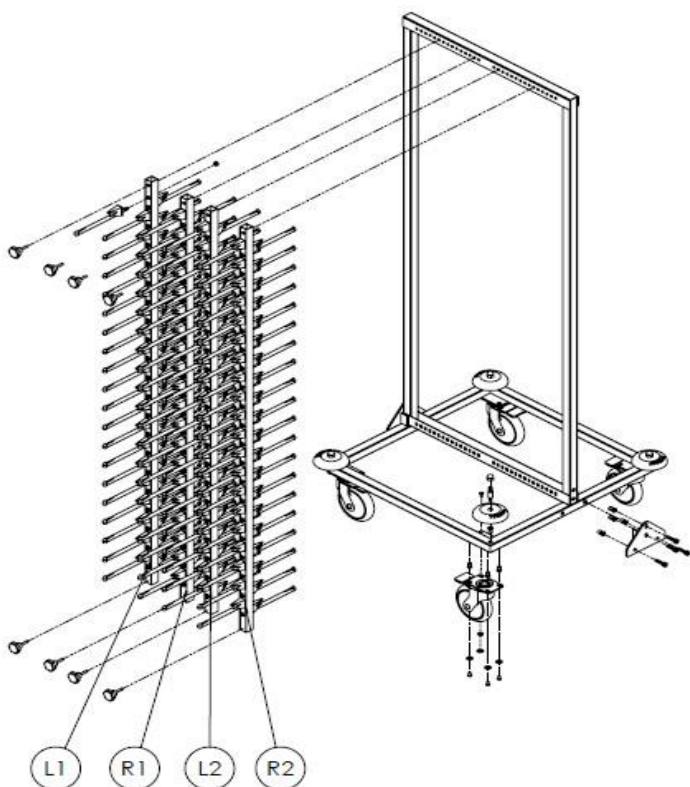

### 2.3. Krok 3 / Schritt 3 / Step 3

	Element / Artikel / Item	Ilość / Menge / Quantity
R1	1-Profil prawy / 1-Profil Rechts / 1-Profile Right	1
L2	2-Profil lewy / 2-Profil links / 2-Profile Left	1
8	Śruby motylkowe / Schmetterlingsschrauben / Butterfly screws	8

Otwory montażowe R1 i L2 / R1 und L2 Einbaulöcher / R1 and L2 Fitting Holes

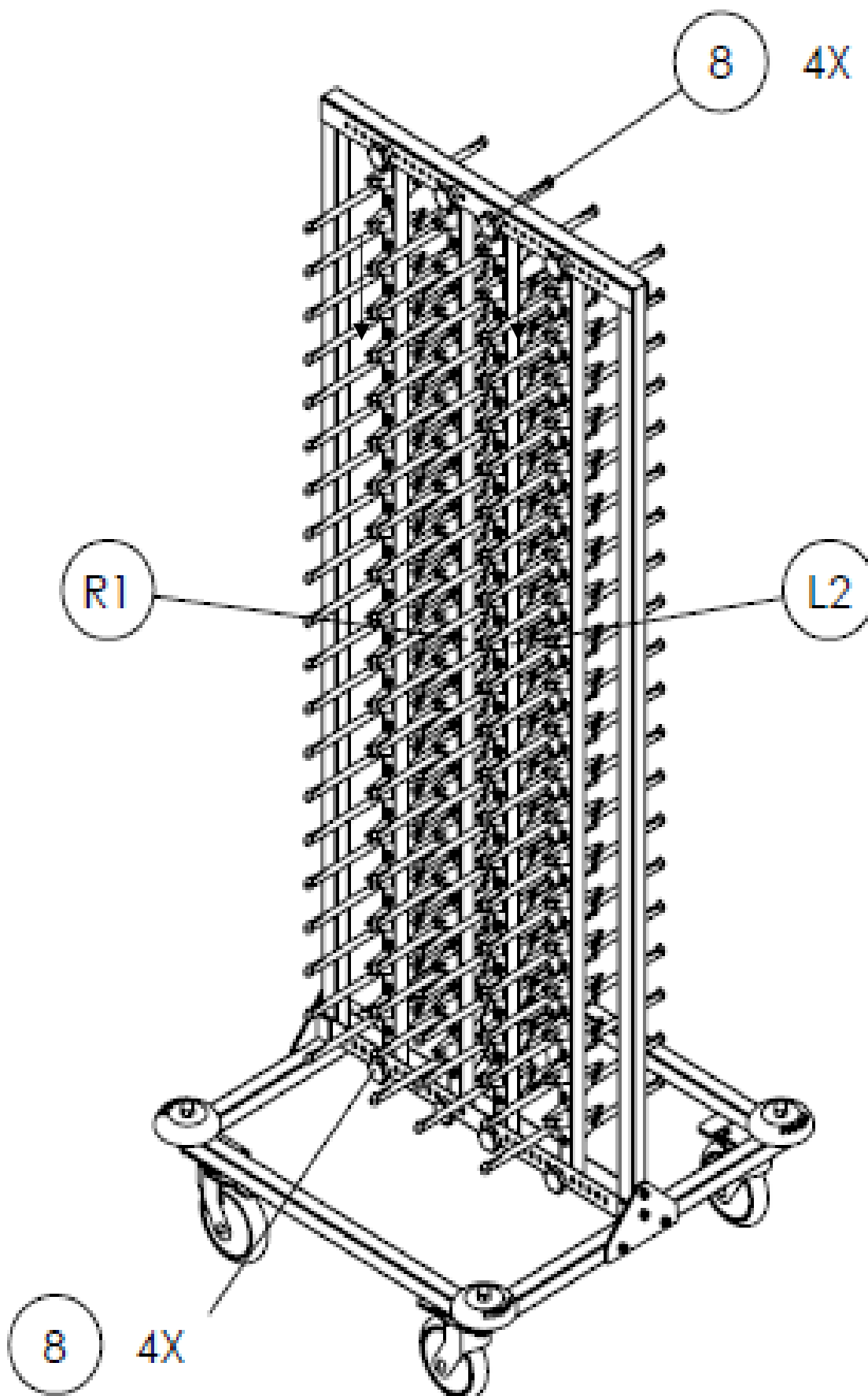

#### 2.4. Krok 4 / Schritt 4 / Step 4

	Element / Artikel / Item	Ilość / Menge / Quantity
R2	2-Profil prawy / 2-Profil Rechts / 2-Profile Right	1
L1	1-Profil lewy / 1-Profil links / 1-Profile Left	1
8	Śruby motylkowe / Schmetterlingschrauben / Butterfly screws	8

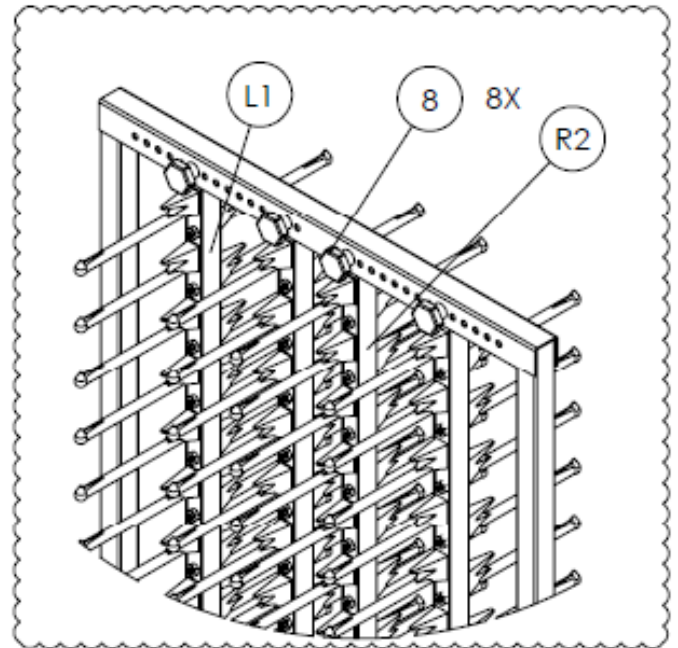
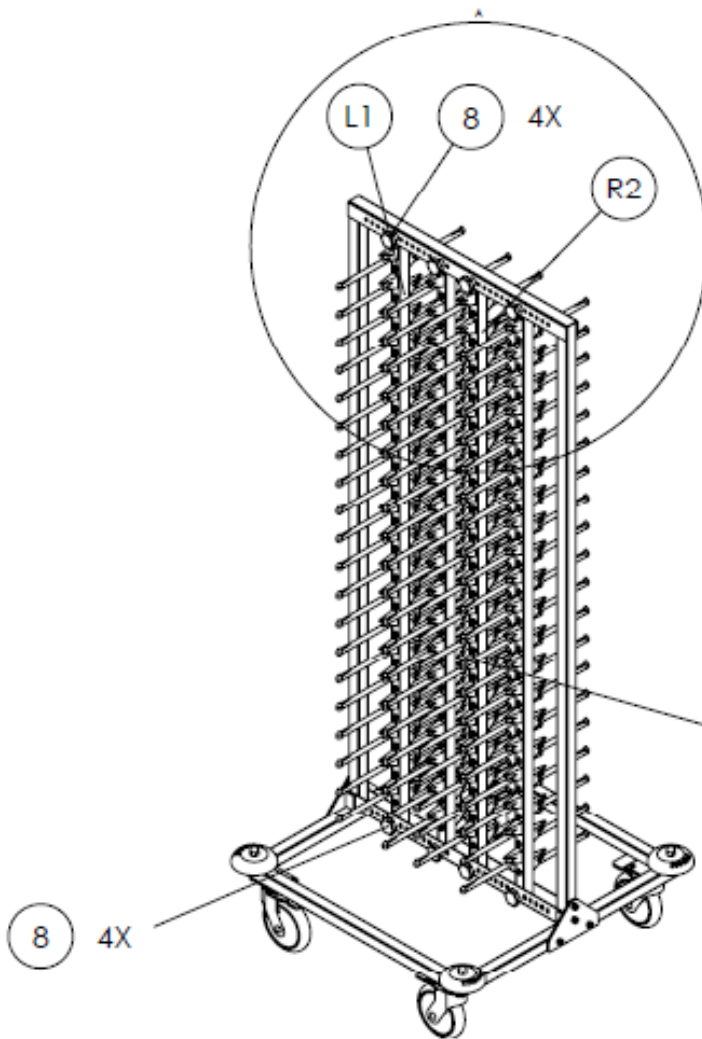

Profile L1 i R2 w zależności od średnicy talerzy należy zamontować w odpowiednich otworach.

Die Profile L1 und R2 werden je nach Durchmesser der Scheiben in die entsprechenden Löcher eingesetzt.

Profiles L1 and R2, depending on the diameter of the discs, should be installed in the corresponding holes.







**Stalgast Sp. z o.o.**

**Plac Konesera 9, Budynek O, 03-736 Warszawa**

**tel.: 22 517 15 75    fax: 22 517 15 77**

**www.stalgast.com    email: stalgast@stalgast.com**

**• DE •**

**Stalgast GmbH  
Konsul-Smidt-Str. 76 a  
28217 Bremen  
Tel.: +49 421 9898066-1  
stalgast@stalgast.de  
www.stalgast.de**

**• EN •**

**Tel.: +48 22 509 30 77  
export@stalgast.com  
www.stalgast.eu**

**• FR • ES •**

**Tel.: +48 22 509 30 55  
export@stalgast.com  
www.stalgast.eu**